

POWERFLEX®

PART NUMBER

PFF85-502G-5

DESCRIPTION

FRONT WISHBONE REAR BUSH ANTI-LIFT & CASTER OFFSET

INSTALLATION GUIDE

Contents (parts per pack):

- | | |
|--|-----------------------|
| 2 x Aluminium Brackets and Polyurethane Bushes | 4 x Zinc Plated Bolts |
| 2 x Polyurethane Inner Bushes | 4 x Spring Washers |
| 1 x PTFE/Silicone Grease | 2 x Spacer Plates |

Please read the complete fitting instructions and check package components before fitment. These fitting instructions are to be used as a guide and in conjunction with workshop manual.

It is recommended that:

- all work to be carried out by a licensed technician;
 - all safety precautions adhered to;
 - wheel alignment to be checked and adjusted as required after any suspension work.
- All fasteners must be tensioned to manufacturer's torque settings.

Fitting Instructions:

1. Remove front wishbones from the car and remove the original bracket and bush from the wishbone.
2. Clean any dirt or corrosion from the end of the wishbone and remove any sharp edges using a file.
3. Re-fit the wishbone to the car by locating the front bush into position.
4. Apply some of the supplied grease to the bore of the bush and insert the black polyurethane inner bush into the larger outer bush.
5. When fitting the new bracket, attach the spacer plate in between the new bracket and the subframe of the car as seen on Figure 2. Make note of the correct orientation for each bracket (see Figure 1).
6. Use a new replacement stretch bolt (OEM P/N: N10694701) in the front hole position and fit the washers, ensuring the flat washer is fitted in between the spring washer and the bracket.
7. Test drive the vehicle and perform full wheel alignment check and adjustment. Tighten hardware to recommended torque settings.



Left-hand wishbone fitment shown



Left-hand of car



Right-hand of car

Figure 1

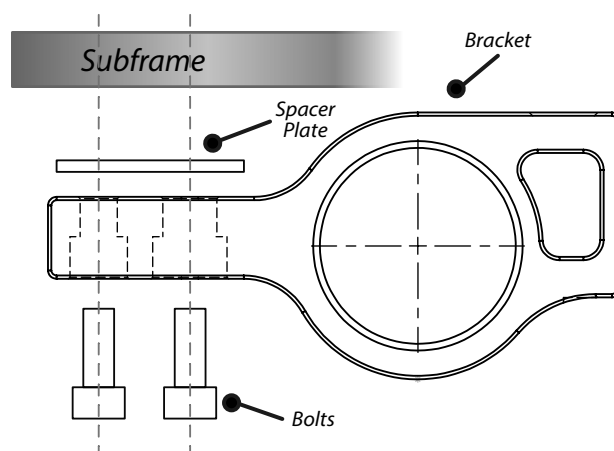

Figure 2